



TECHNICAL DATA SHEET

10/1999



advanced coating systems for
technologically advanced ships

The evolution of technologies in shipbuilding requires of vessels to render long operative periods without frequent maintenance. The necessity to build different vessels for different purposes has guided the demand in this field towards products providing:

- an easy application
- reliability
- long lasting characteristics and easy maintenance
- competitive costs.

FLUID FILM - products satisfy the demand for products that meet such requirements and conform to the rules of the Register of Shipping.

The constituents of wool wax compounds, forming the basis of **FLUID FILM** are chemically modified to produce substances which are highly polar and form a tenacious moisture barrier to the metal face. Penetrants are provided to insure migration and penetration of the beneficial compounds through existing rust/scale, subsequently softening the rust particles which are absorbed by the soft coating.

As time progresses the coating becomes tougher and the underlying metal surface remains fully protected against progressive corrosion.

FLUID FILM coatings are recommended for all marine applications where a permanently soft coating is not objectionable. It is not recommended for use in areas of abrasion, such as the outside of a ship's hull.

Perhaps the greatest single benefit to be derived from use of **FLUID FILM**, aside from its protective properties, is the fact that once in place on the metal surface it remains until chemically or mechanically removed a continuously soft, non-drying barrier against metal deterioration.

Extremely low oral toxicity, minimal skin irritation, and negative eye irritation are other advantages of **FLUID FILM**.

The high flash point and the absence of solvents assure safety during application. These unique products have now been in use all over the world for more than 50 years.

On the following pages brief descriptions are given of the various forms of **FLUID FILM** coatings and wire rope dressings.

ALFRED HODT KORROSIONSSCHUTZ GMBH maintain a staff of qualified technical representatives whose skill in survey and subsequent supervision of coating application, assure the owner of complete corrosion protection for his ship.

HODT Korrosionsschutz GmbH

Flurstraße 8, 21465 Wentorf b. Hamburg
www.hodt.de

Telefon
+49-40-72904030

Telefax
+49-40-72904059

E-mail
info@hodt.de



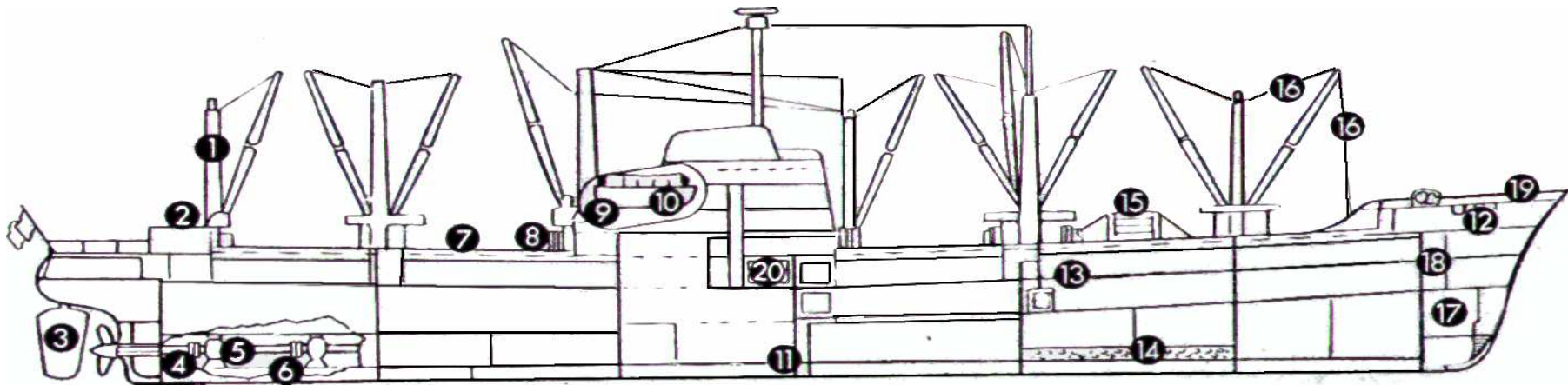

Stem to Stern - Trunk to Keel

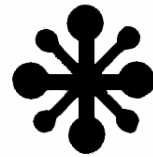

Complete Corrosion Control

FLUID FILM COATINGS

Gel (BW)

Gel form, pigmented white

Gel (WRN-EP) (WRL)
Wire Rope Preservative

Higher viscosity gel

Liquid A

Thick liquid for spray or brush

Liquid AR

Thick liquid for spray or brush

Areosols:
AS-R

To protect metal from rust and corrosion

Below are listed a number of places on board ship where FLUID FILM products may be used to advantage:

<u>LOCATION</u>	<u>RECOMMENDED MATERIAL</u>
1. Kingpost interiors	Gel B (white)
2. Stays and other standing rigging	Gel WRN-EP, WRL, WRO-EP
3. Rudders and bilge keels	Liquid A
4. Shaft alley recesses	Gel B, WRN-EP, WRO-EP
5. Shaft bearing pedestals	Gel WRN-EP
6. Shaft alley	Gel B, WRN-EP
7. Wooden decks	Gel B (as a bedding compound)
8. Hatch covers interiors	Gel B, WRN-EP, WRO-EP
9. Boat davits	Gel B, WRN-EP, WRO-EP
10. Boats	Gel B, International Orange (in accessible areas)
11. Voids, cofferdams and drain wells	Gel B, Liquid A, Liquid AR
12. Deck machinery	Gel B, WRN-EP, Liquid AR
13. Cargo holds, as bedding under wood ceilings	Gel B
14. Permanent ballast tanks	Gel B, Liquid A, Liquid AR
15. Cargo grips, hatch dogs	Gel B or Aerosol
16. Running rigging	Gel WRN-EP, WRL, WRO-EP
17. Chain lockers	Gel B, Liquid AR
18. Anchor chains	Liquid A, Liquid AR
19. Brine systems	Gel B